

Please write clearly in block capitals.

Centre number

--	--	--	--	--

Candidate number

--	--	--	--

Surname

---

Forename(s)

---

Candidate signature

---

I declare this is my own work.

# GCSE MATHEMATICS

# F

Foundation Tier      Paper 2 Calculator

Thursday 3 November 2022      Morning      Time allowed: 1 hour 30 minutes

## Materials

For this paper you must have:

- a calculator
- mathematical instruments
- the Formulae Sheet (enclosed).

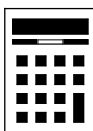

## Instructions

- Use black ink or black ball-point pen. Draw diagrams in pencil.
- Fill in the boxes at the top of this page.
- Answer **all** questions.
- You must answer the questions in the spaces provided. Do not write outside the box around each page or on blank pages.
- If you need extra space for your answer(s), use the lined pages at the end of this book. Write the question number against your answer(s).
- Do all rough work in this book. Cross through any work you do not want to be marked.

## Information

- The marks for questions are shown in brackets.
- The maximum mark for this paper is 80.
- You may ask for more answer paper, graph paper and tracing paper. These must be tagged securely to this answer book.

For Examiner's Use	
Pages	Mark
2–3	
4–5	
6–7	
8–9	
10–11	
12–13	
14–15	
16–17	
18–19	
20–21	
22–23	
24–25	
26	
<b>TOTAL</b>	

## Advice

In all calculations, show clearly how you work out your answer.



N 0 V 2 2 8 3 0 0 2 F 0 1

Answer **all** questions in the spaces provided.

Do not write  
outside the  
box

- 1** Circle the number that is a multiple of 25 **[1 mark]**

55

65

75

85

- 2** Circle the value of the digit 3 in the number 10.23 **[1 mark]**

 $\frac{3}{1000}$  $\frac{3}{100}$  $\frac{3}{10}$ 

3

- 3** Circle the lowest of these temperatures. **[1 mark]**

 $-2.1^{\circ}\text{C}$  $0.4^{\circ}\text{C}$  $-5^{\circ}\text{C}$  $1^{\circ}\text{C}$ 

- 4 Circle the letter of the shape that has **exactly one** line of symmetry. [1 mark]

P

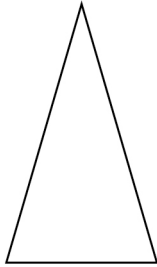

Q

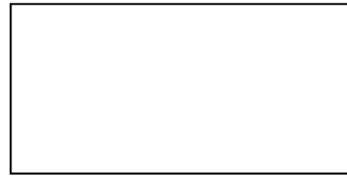

R

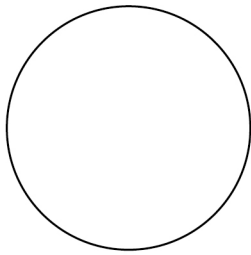

S

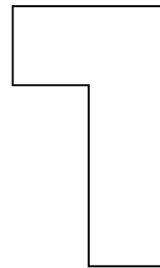

Turn over for the next question



5 (a) Simplify fully  $d \times d$

[1 mark]

Answer \_\_\_\_\_

5 (b) Simplify fully  $n \div n$

[1 mark]

Answer \_\_\_\_\_

5 (c) Simplify fully  $\frac{1}{3} \times 6t$

[1 mark]

Answer \_\_\_\_\_



- 6 (a) Write a number in the box to make the calculation correct.

[1 mark]

$$16 \div \square = 0.016$$

- 6 (b) Write a number in the box to make the calculation correct.

[1 mark]

$$18.4 + 3.9 + \square = 27$$

- 6 (c) Write a fraction in the box to make the calculation correct.

[1 mark]

$$\frac{1}{2} \times \square = \frac{1}{8}$$

- 6 (d) Write the **same** number in both boxes to make the calculation correct.

[1 mark]

$$\square \times \square = 361$$





7 Three groups of people, A, B and C, have taken driving tests.

7 (a) Here is information about the number of tests taken by the people in A.

**Group A**

Key:  represents 4 people

<b>One test</b>	
<b>Two tests</b>	
<b>Three tests</b>	

Here is information about the number of tests taken by the people in B.

**One test** Half the number in A who have taken one test.

**Two tests** 4 fewer than the number in A who have taken two tests.

**Three tests** 10 more than the number in A who have taken three tests.

Complete this pictogram for the people in B.

**[3 marks]**

**Group B**

Key:  represents 4 people

<b>One test</b>	
<b>Two tests</b>	
<b>Three tests</b>	



- 7 (b) In group C there are 25 people.  
17 of these people have passed a test.  
One person is picked at random from C.

Work out the probability that the person has **not** passed a test.

[2 marks]

---

---

---

Answer \_\_\_\_\_

- 8 Work out the value of  $3r + 4t$  when  $r = 13$  and  $t = -2$

[2 marks]

---

---

---

Answer \_\_\_\_\_

Turn over for the next question

7

Turn over ►



9

Hamish has saved 295 coins.

Each one is a 20p coin.

He gives an equal number of 20p coins to each of his 8 grandchildren.

He gives them as many coins as possible.

How much, in £, does he have left?

**[4 marks]**

---

---

---

---

---

---

---

---

---

---

Answer £ \_\_\_\_\_





**10** Here are two sets of numbers.

**Set A**    2   12   13   27

**Set B**    1   15   16   30

One number from Set A is swapped with one number from Set B.  
The total of the numbers in each set is now the same.

Which two numbers are swapped?

**[2 marks]**

---



---



---



---



---

Answer \_\_\_\_\_ and \_\_\_\_\_

**11** Rearrange  $m = p - 5$  to make  $p$  the subject.  
Circle your answer.

**[1 mark]**

$$p = \frac{m}{5}$$

$$p = m + 5$$

$$p = 5m$$

$$p = m - 5$$



**12** Here is the distance-time graph for a car between 1 pm and 3 pm

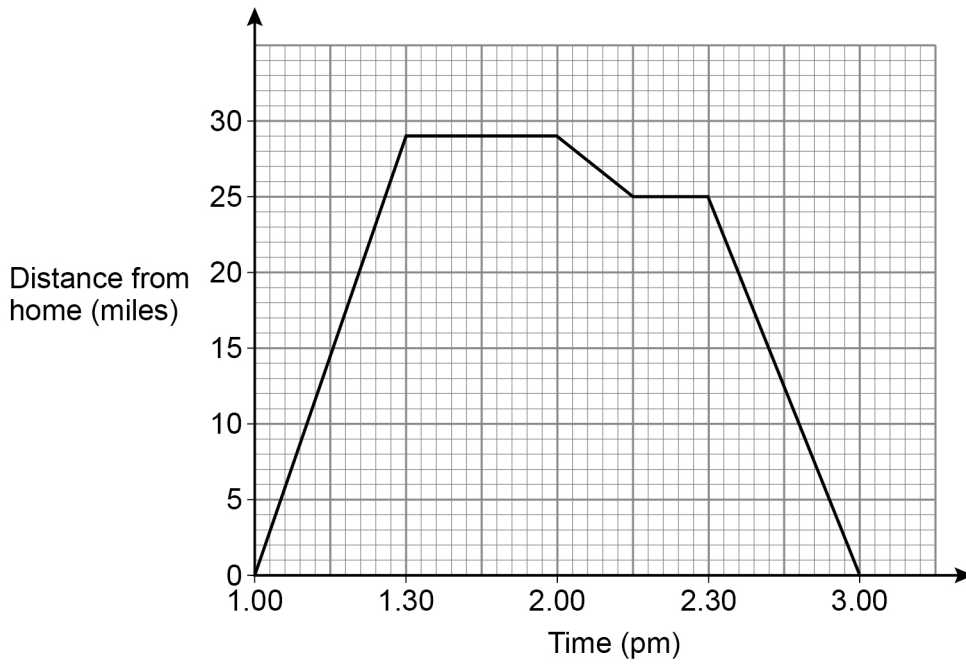

**12 (a)** Work out the **total** time that the car is **not** moving between 1 pm and 3 pm  
State the units of your answer.

**[2 marks]**

---



---



---

Answer \_\_\_\_\_

**12 (b)** Work out the **total** distance the car travels between 1 pm and 3 pm

**[2 marks]**

---



---



---

Answer \_\_\_\_\_ miles



13

$A$  and  $B$  are points on a circle.

$C$  is the centre of the circle.

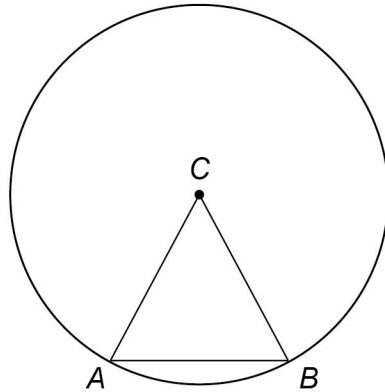

Not drawn  
accurately

Tick **one** box for each statement.

[3 marks]

	Definitely true	Might be true	Cannot be true
Line $AB$ is a tangent to the circle	<input type="checkbox"/>	<input type="checkbox"/>	<input type="checkbox"/>
$AC$ is an arc of the circle	<input type="checkbox"/>	<input type="checkbox"/>	<input type="checkbox"/>
Triangle $ABC$ is equilateral	<input type="checkbox"/>	<input type="checkbox"/>	<input type="checkbox"/>

Turn over for the next question

Turn over ►



- 14** To travel to a festival, a group of people will hire a minibus.  
This formula has all costs in £

$$\text{Cost per person} = \frac{165 + \text{cost of the minibus}}{\text{number of people in the group}}$$

- 14 (a)** With 12 people in the group, the cost of the minibus will be £567  
Work out the cost per person.

**[2 marks]**

---



---



---

Answer £ \_\_\_\_\_

- 14 (b)** With 15 people in the group, they will hire a different minibus.  
The cost per person will be £50  
Work out the cost of this minibus.

**[3 marks]**

---



---



---



---



---

Answer £ \_\_\_\_\_



15

The sketch shows

the line  $y = x$ 

line A, which is vertical

line B, which is horizontal.

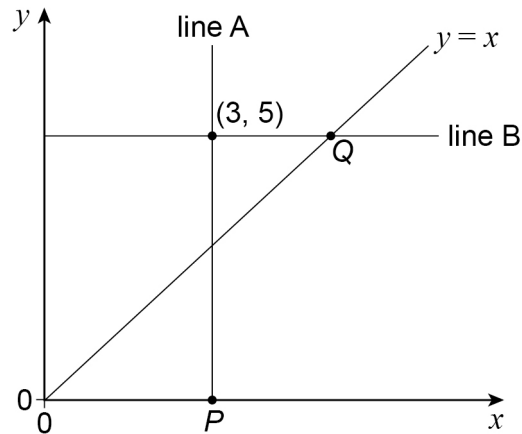
The point  $(3, 5)$  is on both line A and line B.Write down the coordinates of  $P$  and  $Q$ .**[2 marks]** $P$  ( \_\_\_\_\_ , \_\_\_\_\_ )     $Q$  ( \_\_\_\_\_ , \_\_\_\_\_ )**Turn over for the next question****Turn over ►**

- 16** Some people were asked for the main way they listen to music.  
A pie chart is drawn to represent their answers.

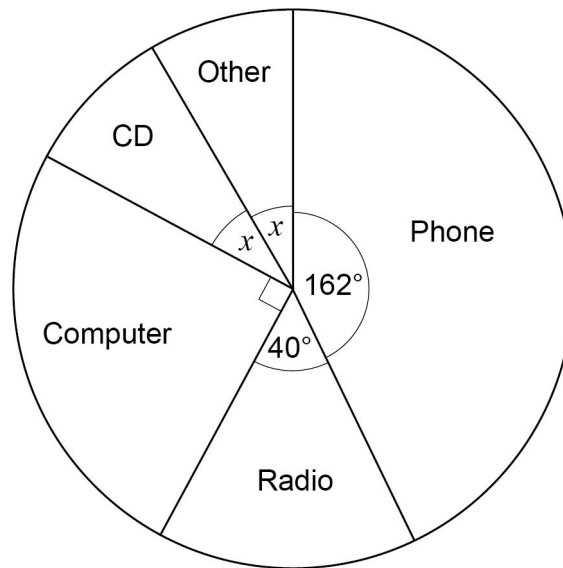

- 16 (a)** Work out the size of angle  $x$ .

**[2 marks]**

---

---

---

Answer \_\_\_\_\_ degrees



16 (b) 135 people said Computer.

How many people said Phone?

[3 marks]

---

---

---

---

---

Answer \_\_\_\_\_

17 Complete this statement.

[1 mark]

$10^8 =$  \_\_\_\_\_ million

Turn over for the next question



**18** A football team plays two matches.

**18 (a)** For the first match, 40 000 tickets are sold.

Assume that each ticket costs £38.50

Work out the total amount of money from ticket sales for this match.

**[2 marks]**

---

---

---

---

Answer £ \_\_\_\_\_

**18 (b)** In fact, for the first match,  
some of the tickets cost less than £38.50  
and  
some of the tickets cost more than £38.50

What does this mean about the total amount of money from ticket sales for this match?

Tick **one** box.

**[1 mark]**

It will be more than the answer to part (a)

It will be the same as the answer to part (a)

It will be less than the answer to part (a)

It is not possible to tell





**18 (c)** For the second match, the number of tickets sold increases from 40 000 to 55 000

Is the increase in tickets sold **more** than 35% ?

You **must** show your working.

**[3 marks]**

---

---

---

---

---

---

---

---

**19** On a train, there are between 60 and 70 people.

The ratio of adults to children is 5 : 4

Work out the **total** number of people on the train.

**[2 marks]**

---

---

---

---

Answer \_\_\_\_\_



20

The composite bar chart shows information about the **percentage** of drinks sold by a café in 2007 and 2019

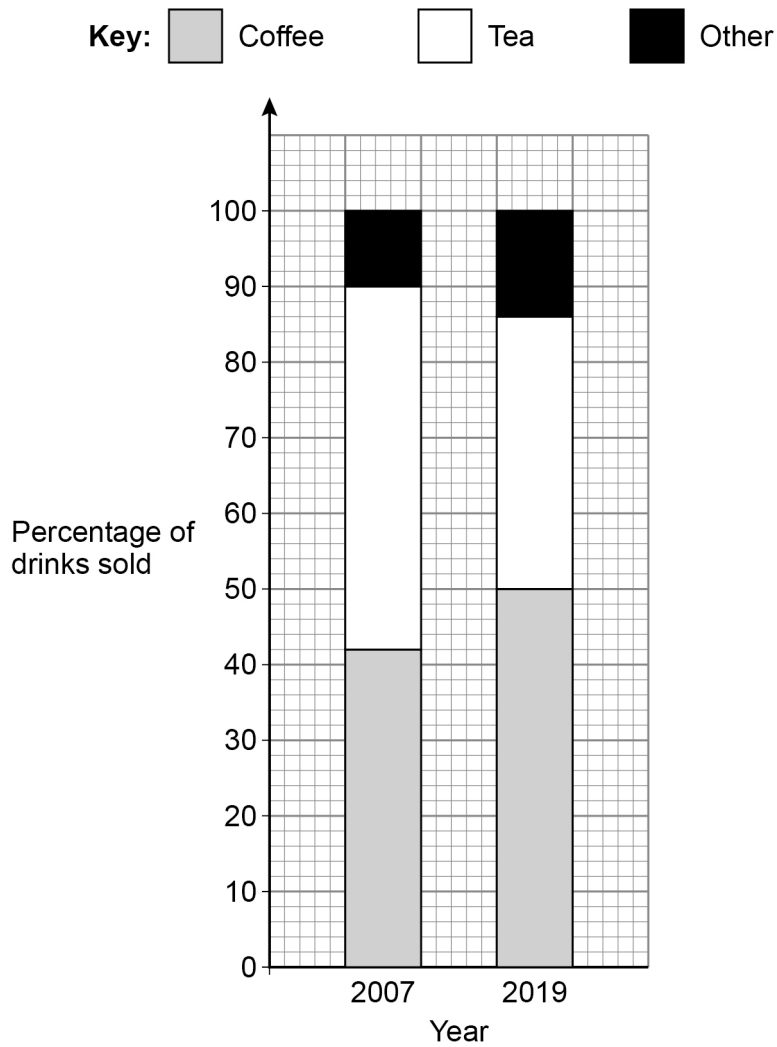

20 (a) In 2007 the café sold a total of 24 000 drinks.

How many **more** teas than coffees were sold?

[2 marks]

---



---



---



---

Answer \_\_\_\_\_



20 (b) Were more coffees sold at the café in 2019 than in 2007 ?

Tick a box.

Yes

No

Cannot tell

Give a reason for your answer.

[1 mark]

---



---



---

21 (a)  $k$  is a whole number between 40 and 50

The cube root of  $k$  is 3, to the nearest whole number.

Work out the **largest** possible value of  $k$ .

[2 marks]

---



---



---



---

Answer \_\_\_\_\_

21 (b) Fay tries to solve  $x^2 = 100$

She says,

“The only possible value of  $x$  is 10”

Give a reason why she is **not** correct.

[1 mark]

---



---

Turn over ►



22 (a) Here is a cuboid.

$w$ ,  $x$  and  $y$  are **different** whole numbers.

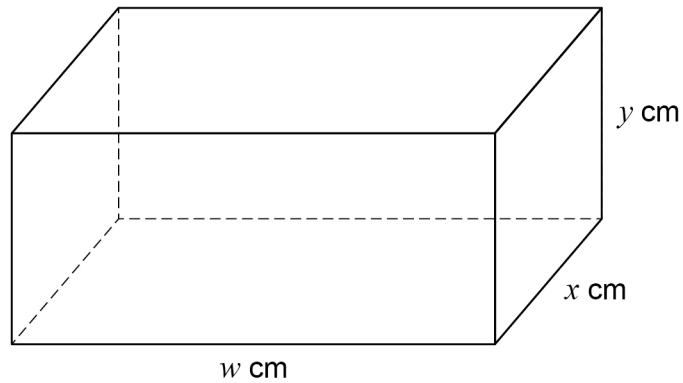

The total length of **all** the edges of the cuboid is 80 cm

The volume is **greater** than  $200 \text{ cm}^3$

Work out one possible set of values for  $w$ ,  $x$  and  $y$ .

**[2 marks]**

---

---

---

---

---

---

---

$w =$  \_\_\_\_\_  $x =$  \_\_\_\_\_  $y =$  \_\_\_\_\_



22 (b) Here is a solid cube.

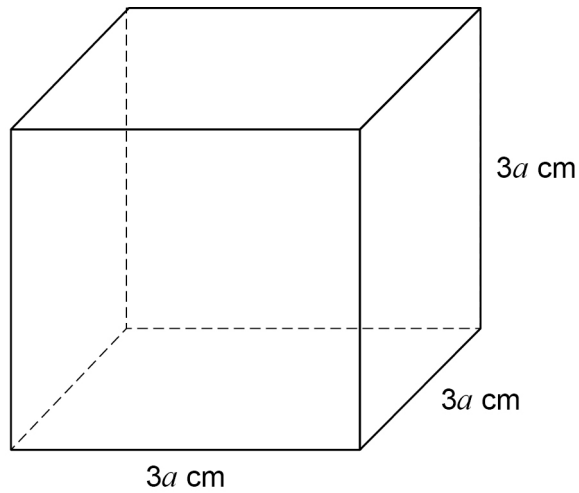

Circle the expression for the **total** surface area in  $\text{cm}^2$

[1 mark]

$36a$

$54a$

$36a^2$

$54a^2$

23 The equation of a line is  $y = 3x - 6$

Circle the coordinates of the  $y$ -intercept.

[1 mark]

$(0, -6)$

$(-6, 0)$

$(0, 3)$

$(3, 0)$



- 24 (a)** Work out  $2.8^4 + \sqrt{158.76}$   
Give your answer as a decimal.

[2 marks]

---

---

---

Answer \_\_\_\_\_

- 24 (b)** Work out  $\frac{6.09 \times 10^{14}}{4.2 \times 10^9}$   
Give your answer in standard form.

[2 marks]

---

---

---

Answer \_\_\_\_\_

- 25** A tank contains 40 litres of water.

- 25 (a)** Water leaks out of the tank at a rate of 1.2 litres per minute.  
The leak is stopped after 20 minutes.  
Show that, when the leak is stopped, the tank contains 16 litres of water.

[1 mark]

---

---

---

---



**25 (b)** The tank is refilled with water from a tap.  
The graph shows the amount of water in the tank **after** the leak is stopped.

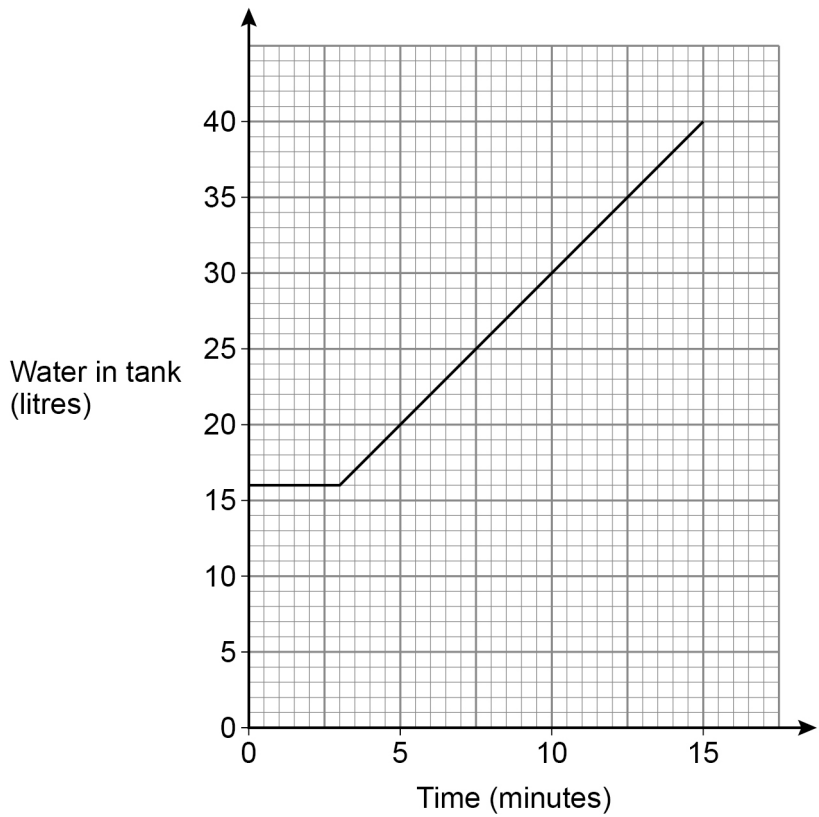

Complete this report by writing a number in each answer space.

**[3 marks]**

**Report**

\_\_\_\_\_ minutes after the leak is stopped, the tap starts to refill the tank.

The rate at which the tank refills is \_\_\_\_\_ litres per minute.

---



---



---



---



26

Here is a triangle.

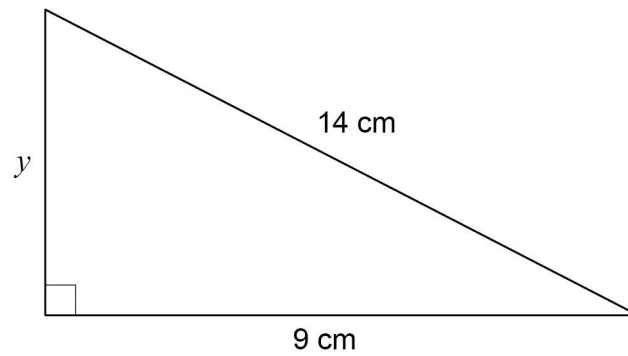
Not drawn  
accuratelyUse Pythagoras' theorem to work out the value of  $y$ .

Give your answer as a decimal.

**[3 marks]**

---

---

---

---

---

---

 $y =$  \_\_\_\_\_  $\text{cm}$ 



27

The length of this rectangle is 6 times the width.

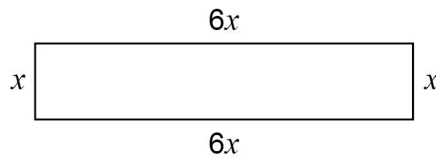

Not drawn  
accurately

Two of these rectangles are joined, with no overlap, to make this L-shape.

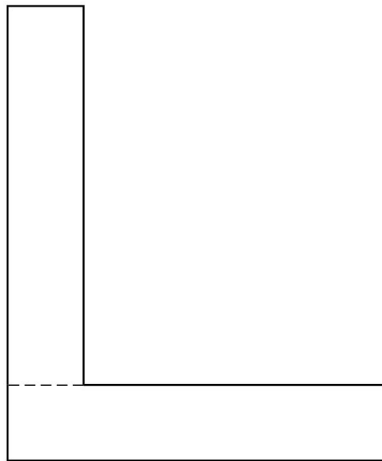

Not drawn  
accurately

The perimeter of the L-shape is 98.8 cm

Work out the value of the perimeter of **one** of the rectangles.

**[4 marks]**

---



---



---



---



---



---



---



---



---

Answer \_\_\_\_\_ cm

7

Turn over ►



28 Written as the product of prime factors,

$$12\,600 = 2^3 \times 3^2 \times 5^2 \times 7$$

and

$$14\,112 = 2^5 \times 3^2 \times 7^2$$

Work out the highest common factor (HCF) of 12 600 and 14 112

Give your answer as an integer.

**[2 marks]**

---

---

---

---

Answer \_\_\_\_\_

**END OF QUESTIONS**



**There are no questions printed on this page**

*Do not write  
outside the  
box*

**DO NOT WRITE ON THIS PAGE  
ANSWER IN THE SPACES PROVIDED**











**There are no questions printed on this page**

*Do not write  
outside the  
box*

**DO NOT WRITE ON THIS PAGE  
ANSWER IN THE SPACES PROVIDED**

**Copyright information**

For confidentiality purposes, all acknowledgements of third-party copyright material are published in a separate booklet. This booklet is published after each live examination series and is available for free download from [www.aqa.org.uk](http://www.aqa.org.uk).

Permission to reproduce all copyright material has been applied for. In some cases, efforts to contact copyright-holders may have been unsuccessful and AQA will be happy to rectify any omissions of acknowledgements. If you have any queries please contact the Copyright Team.

Copyright © 2022 AQA and its licensors. All rights reserved.

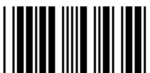

3 2



2 2 B G 8 3 0 0 / 2 F

IB/M/Nov22/8300/2F