

Please write clearly in block capitals.

Centre number

--	--	--	--	--

Candidate number

--	--	--	--

Surname

---

Forename(s)

---

Candidate signature

---

I declare this is my own work.

# GCSE MATHEMATICS

# H

Higher Tier

Paper 3 Calculator

Time allowed: 1 hour 30 minutes

## Materials

For this paper you must have:

- a calculator
- mathematical instruments
- the Formulae Sheet (enclosed).

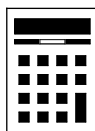

## Instructions

- Use black ink or black ball-point pen. Draw diagrams in pencil.
- Fill in the boxes at the top of this page.
- Answer **all** questions.
- You must answer the questions in the spaces provided. Do not write outside the box around each page or on blank pages.
- If you need extra space for your answer(s), use the lined pages at the end of this book. Write the question number against your answer(s).
- Do all rough work in this book. Cross through any work you do not want to be marked.

## Information

- The marks for questions are shown in brackets.
- The maximum mark for this paper is 80.
- You may ask for more answer paper, graph paper and tracing paper. These must be tagged securely to this answer book.

For Examiner's Use	
Pages	Mark
2–3	
4–5	
6–7	
8–9	
10–11	
12–13	
14–15	
16–17	
18–19	
20–21	
22–23	
24–25	
26–27	
<b>TOTAL</b>	

## Advice

In all calculations, show clearly how you work out your answer.



Answer **all** questions in the spaces provided.

Do not write  
outside the  
box

**1** Circle the smallest number.

**[1 mark]**

4.31

4. $\dot{3}$

4.301

4.33

**2**

Work out  $\begin{pmatrix} -4 \\ 8 \end{pmatrix} - \begin{pmatrix} 3 \\ -2 \end{pmatrix}$

Circle your answer.

**[1 mark]**

$\begin{pmatrix} -7 \\ 10 \end{pmatrix}$

$\begin{pmatrix} -7 \\ 6 \end{pmatrix}$

$\begin{pmatrix} -1 \\ 10 \end{pmatrix}$

$\begin{pmatrix} -1 \\ 6 \end{pmatrix}$



3 Here are four scatter graphs.

Graph A

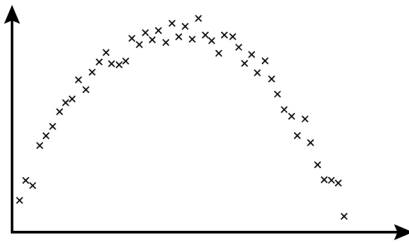

Graph B

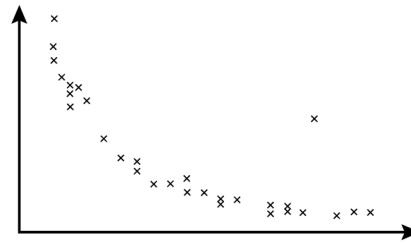

Graph C

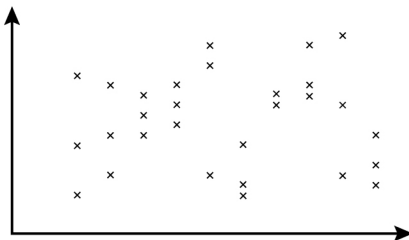

Graph D

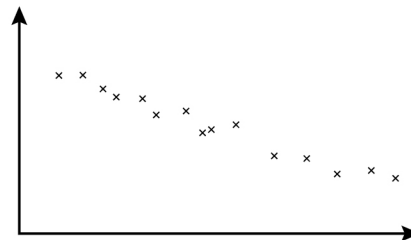

3 (a) For which graph is a straight line of best fit appropriate?  
Circle your answer.

[1 mark]

A

B

C

D

3 (b) Which graph has **one** outlier?  
Circle your answer.

[1 mark]

A

B

C

D



- 4 Use trigonometry to work out the size of angle  $x$ .

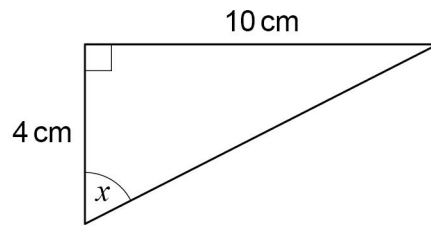

Not drawn  
accurately

[3 marks]

---

---

---

---

---

---

---

$$x = \text{_____}^\circ$$



5

Laura works in a shop.

The table shows the number of hours she works on two weekends.

	Saturday	Sunday
Weekend 1	3	2
Weekend 2	$5\frac{1}{2}$	$3\frac{1}{2}$

Work out the percentage increase in her **total** hours from Weekend 1 to Weekend 2**[3 marks]**

---

---

---

---

---

---

---

Answer \_\_\_\_\_ %

**Turn over for the next question**

6 Here is a sketch of the curve  $y = x^2 - 4x - 5$

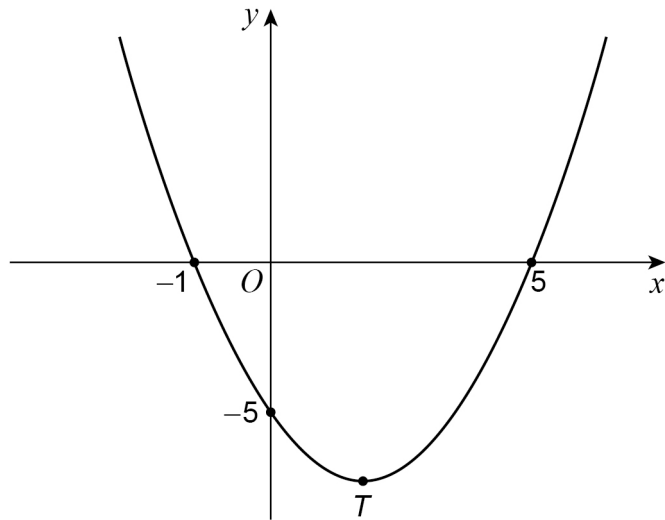

6 (a) Write down the **two** roots of  $x^2 - 4x - 5 = 0$

[1 mark]

Answer \_\_\_\_\_ and \_\_\_\_\_

6 (b) Work out the coordinates of  $T$ , the turning point of the curve.

[2 marks]

---

---

---

Answer ( \_\_\_\_\_ , \_\_\_\_\_ )



7

A is an **arithmetic** progression.

Here are the first four terms.

13                  16                  19                  22

G is a **geometric** progression.

Here are the first four terms.

2                  4                  8                  16

$$n\text{th term of A} = 8\text{th term of G}$$

Work out the value of  $n$ .**[4 marks]**

---

---

---

---

---

---

---

---

$$n = \underline{\hspace{10em}}$$



8

Information about two fridge-freezers, A and B, is shown.

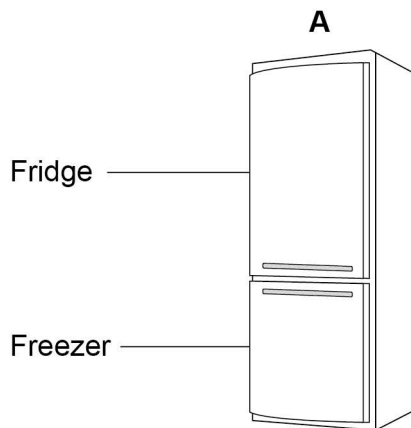
**Total** capacity is 330 litres

fridge capacity : freezer capacity = 3 : 2

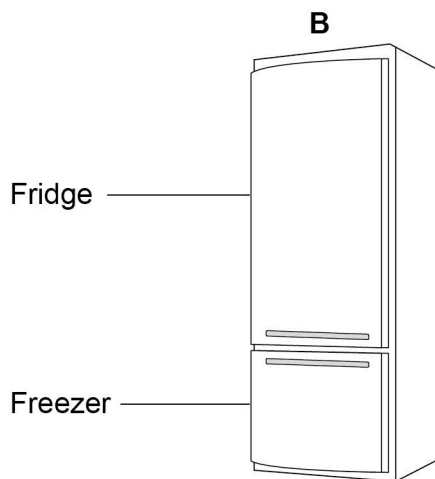
**Fridge** capacity is 294 litres

fridge capacity : freezer capacity = 7 : 3





Grace buys one of these fridge-freezers.  
She buys the one with the greater **freezer** capacity.

Which one does she buy?  
You **must** show your working.

[4 marks]

---

---

---

---

---

---

---

---

---

---

---

---

---

---

---

---

---

---

---

---

---

---

---

Answer \_\_\_\_\_

Turn over for the next question

4
---

Turn over ►



9

Tom and Adil are the two runners in a 200-metre race.

Tom completes the race in 24 seconds.

Adil completes the race at an average speed of 28.8 kilometres per hour.

Who wins the race?

You **must** show your working.

**[3 marks]**

---

---

---

---

---

---

---

---

---

---

Answer \_\_\_\_\_



**10** The mass of a baby is 3.6 kilograms to 1 decimal place.

What is the error interval for the mass in kilograms?

Tick **one** box.

[1 mark]

$$3.5 \leq \text{mass} \leq 3.6$$

$$3.55 \leq \text{mass} \leq 3.65$$

$$3.5 \leq \text{mass} < 3.6$$

$$3.55 \leq \text{mass} < 3.65$$

**11** A quadrilateral has angles  $70^\circ$ ,  $110^\circ$ ,  $130^\circ$  and  $50^\circ$

Circle the possible type of quadrilateral.

[1 mark]

kite

parallelogram

rhombus

trapezium

Turn over for the next question

Turn over ►



12 (a)  $B$  is

6 km due South of  $A$

and

6 km due West of  $C$ .

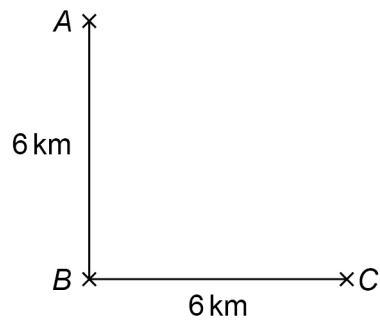

Not drawn  
accurately

Work out the bearing of  $A$  from  $C$ .

[2 marks]

---

---

---

---

Answer \_\_\_\_\_°



12 (b) Here is a scale drawing.

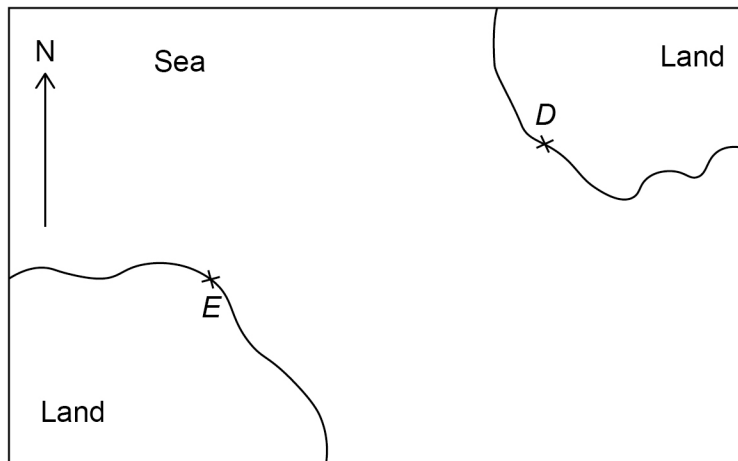

A ship is going to sail from  $D$  to  $E$ .

Mia works out that the ship needs to sail on a bearing of  $068^\circ$

Why must Mia be wrong?

[1 mark]

---



---



---

13 Simplify  $\sqrt{5}a + \sqrt{5}a$

Circle your answer.

[1 mark]

$5a$

$5a^2$

$2\sqrt{5}a$

$\sqrt{10}a$



**14** Students in two classes, A and B, raised money for charity.  
The box plot for class A is shown on the grid.

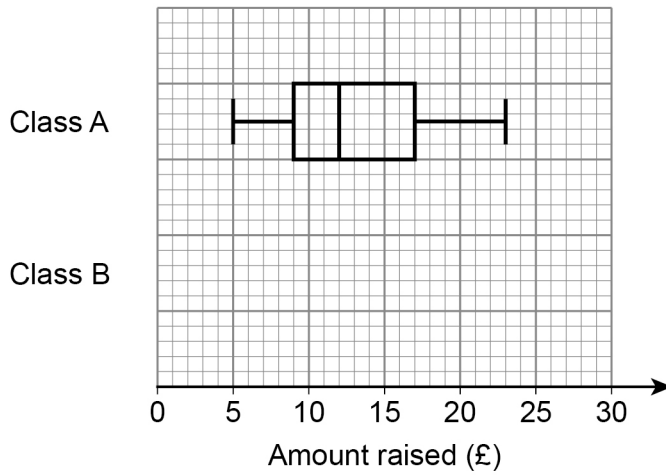

For class B,

- the lowest amount was £3 and the highest amount was £26
- the lower quartile was £11
- the median was £2 greater than the class A median
- the interquartile range was  $1\frac{1}{2}$  times greater than the class A interquartile range.

Draw the box plot for class B on the grid.

**[4 marks]**

---



---



---



---



---



---



15

A town has

a population density of 278 people per km<sup>2</sup>

and

a population of 158 460

$$\text{population density} = \frac{\text{population}}{\text{area}}$$

The population increases to 168 720

Work out the population density after the increase.

**[3 marks]**

---

---

---

---

---

---

---

---

---

---

Answer \_\_\_\_\_ people per km<sup>2</sup>

16 Here is a scale drawing of a reservoir.

**Scale:** 1 cm represents 500 m

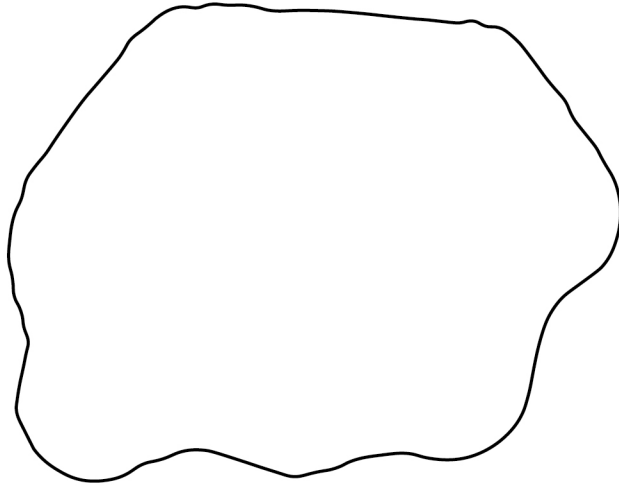

Virat wants to estimate the volume of water in the reservoir.  
He draws on the scale drawing a circle with radius 3 cm

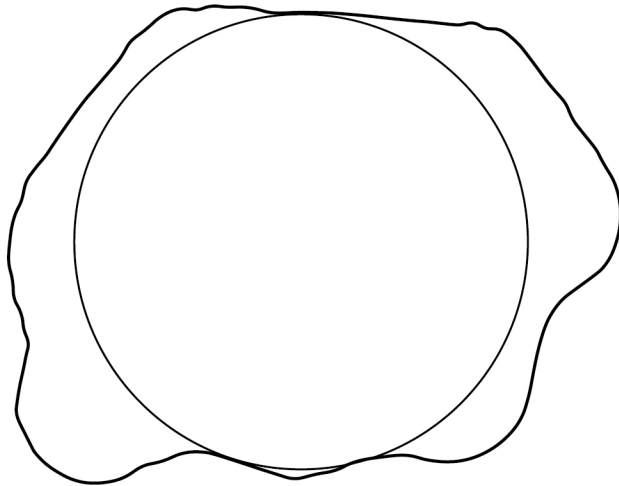



- 16 (a)** Virat estimates the volume of the reservoir by assuming that
- the reservoir is a cylinder whose cross section is the circle
  - the depth of the reservoir is 17 metres.

Work out Virat's estimate in cubic metres.

**[3 marks]**

---



---



---



---



---

Answer \_\_\_\_\_ m<sup>3</sup>

- 16 (b)** In fact,
- the depth of the reservoir is 13.8 metres
  - the reservoir is **not** a cylinder (see diagram).

Which statement about the actual volume of the reservoir is correct?

Tick **one** box.

It is less than Virat's estimate

It is greater than Virat's estimate

It could be less than or greater than Virat's estimate

Give a reason for your answer.

**[2 marks]**

---



---



- 17** In a video game, players make their own character.  
They choose one of each from
- 8 faces
  - 4 bodies
  - 5 hairstyles.

- 17 (a)** How many different characters can be made?

**[2 marks]**

---

---

---

---

Answer \_\_\_\_\_

- 17 (b)** Two characters are made at random.  
What is the probability that they are exactly the same?

**[1 mark]**

---

---

Answer \_\_\_\_\_



- 18  $A$ ,  $B$  and  $C$  are points on a circle, centre  $O$ .  
 $DC$  is a tangent to the circle.

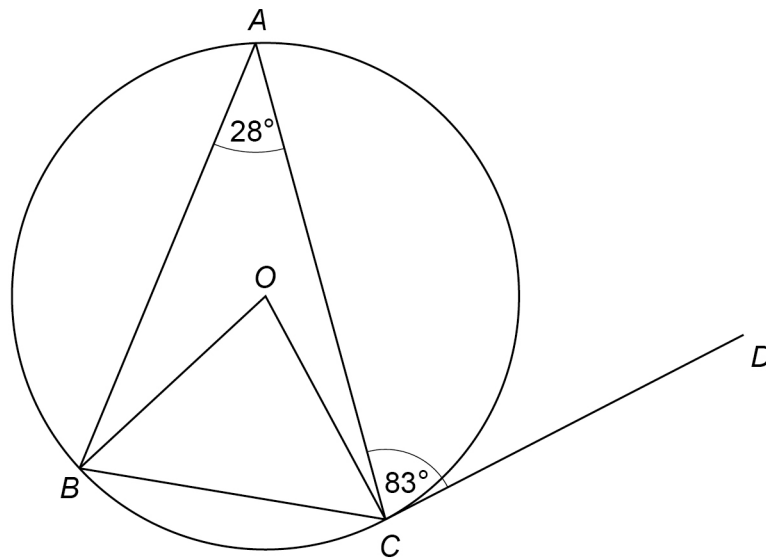

Show that  $\text{angle } ABO : \text{angle } ACO = 3 : 1$

[5 marks]

---



---



---



---



---



---



---



---



---



---



- 19** Here is the plan of the floor of an L-shaped room.  
All lengths are in metres.

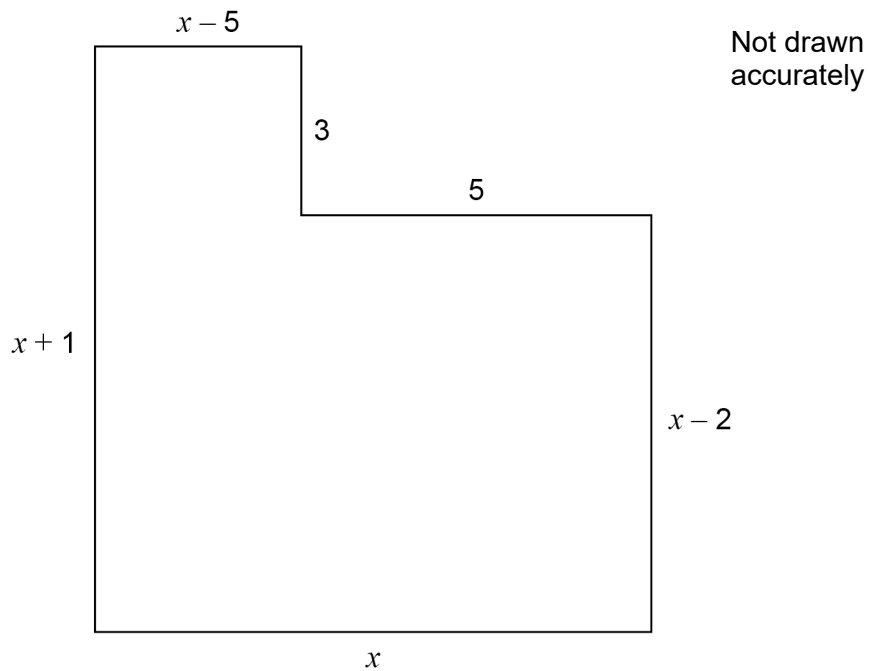

- 19 (a)** The area of the floor is  $75\text{m}^2$

Show that  $x^2 + x - 90 = 0$

**[3 marks]**

---

---

---

---

---

---

---

---

---

---



**19 (b)** By factorising  $x^2 + x - 90$  work out the value of  $x$ .

You **must** show your working

**[2 marks]**

---

---

---

$x =$  \_\_\_\_\_

**20** £2448 is invested in an account at a rate of compound interest.  
One year after the investment there is £2496.96 in the account.

How much is in the account four years after the investment?

**[3 marks]**

---

---

---

---

---

---

---

---

---

---

Answer £ \_\_\_\_\_

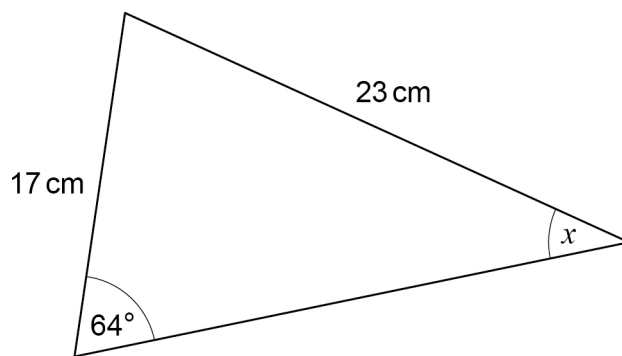

21

Not drawn  
accuratelyUse the sine rule to work out the size of angle  $x$ .**[3 marks]**

---

---

---

---

---

---

---

$$x = \underline{\hspace{10em}}^\circ$$

22

$$f(x) = 3x \quad \text{and} \quad g(x) = x^2$$

Circle the expression for  $fg(x)$ **[1 mark]**

$3x^2$

$9x^2$

$3x^3$

$9x^4$



23

Here are two simultaneous equations.

$$y = x^2 + 7x - c$$

and

$$y = 3x + d$$

There is a solution when  $x = 5$ Work out the value of  $c + d$ **[3 marks]**

---

---

---

---

---

---

---

---

---

---

Answer \_\_\_\_\_

**Turn over for the next question**

7
---

**Turn over ►**

24

Here is a sketch of the graphs of  $y = k^x$  and  $y = x^2 + c$   
 $k$  and  $c$  are positive constants.

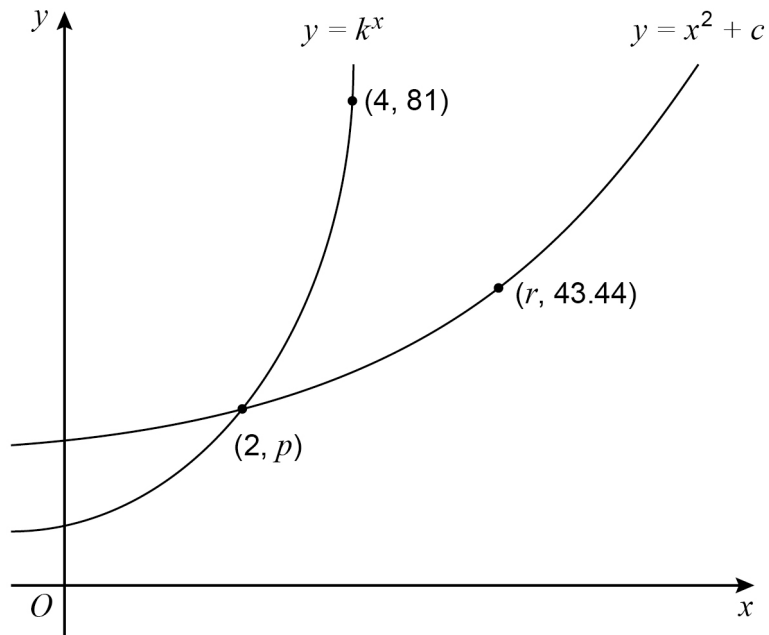

Work out the value of  $r$ .

[4 marks]

---

---

---

---

---

---

---

---

---

---

$r =$  \_\_\_\_\_





**25** A company makes tubes of toothpaste.  
The masses of 80 tubes are checked.  
A histogram is drawn to represent the data.

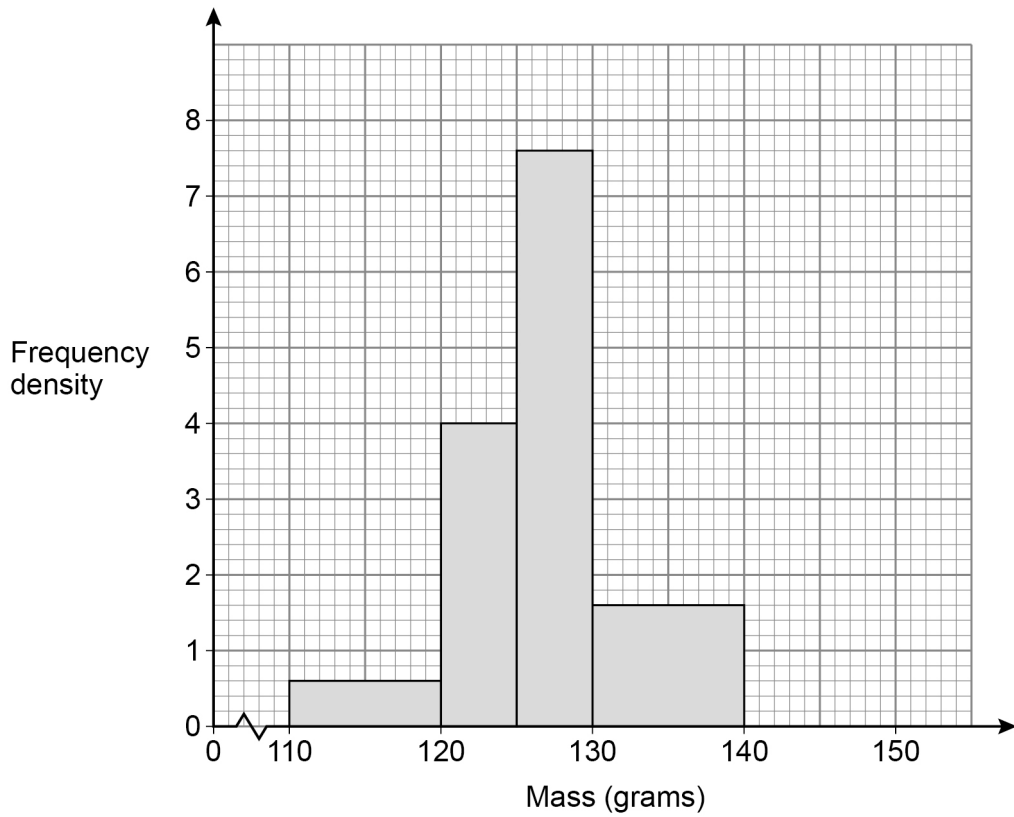

The company makes 28 000 tubes each day.

Estimate how many tubes each day have a mass **less than** 122 grams.

**[4 marks]**

---



---



---



---



---



---



---



---

Answer \_\_\_\_\_

8

Turn over ►



**26**  $Q$  and  $R$  are two numbers.

As a product of prime factors,

$$Q = 2^3 \times 3 \times a^3$$

$$R = 2^4 \times 3^2 \times a^2$$

**26 (a)** The highest common factor (HCF) of  $Q$  and  $R$  is 4056

Work out the value of  $a$ .

**[2 marks]**

---

---

---

---

---

$$a = \underline{\hspace{10em}}$$

**26 (b)** Work out the lowest common multiple (LCM) of  $Q$  and  $R$ .

**[2 marks]**

---

---

---

---

---

---

---

Answer  $\underline{\hspace{10em}}$



27 Expand and simplify fully  $(x - 3)(x - 4)(x + 8)$

[3 marks]

---

---

---

---

---

---

---

---

---

---

---

---

Answer \_\_\_\_\_

**END OF QUESTIONS**



**There are no questions printed on this page**

*Do not write  
outside the  
box*

**DO NOT WRITE ON THIS PAGE  
ANSWER IN THE SPACES PROVIDED**









**There are no questions printed on this page**

*Do not write  
outside the  
box*

**DO NOT WRITE ON THIS PAGE  
ANSWER IN THE SPACES PROVIDED**

**Copyright information**

For confidentiality purposes, all acknowledgements of third-party copyright material are published in a separate booklet. This booklet is published after each live examination series and is available for free download from [www.aqa.org.uk](http://www.aqa.org.uk).

Permission to reproduce all copyright material has been applied for. In some cases, efforts to contact copyright-holders may have been unsuccessful and AQA will be happy to rectify any omissions of acknowledgements. If you have any queries please contact the Copyright Team.

Copyright © 2022 AQA and its licensors. All rights reserved.



3 2



2 2 6 G 8 3 0 0 / 3 H

IB/M/Jun22/8300/3H